

GREYSTONE

ENERGY SYSTEMS INC

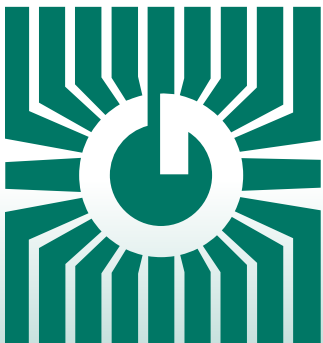

REGULATED DC POWER SUPPLIES PS Series

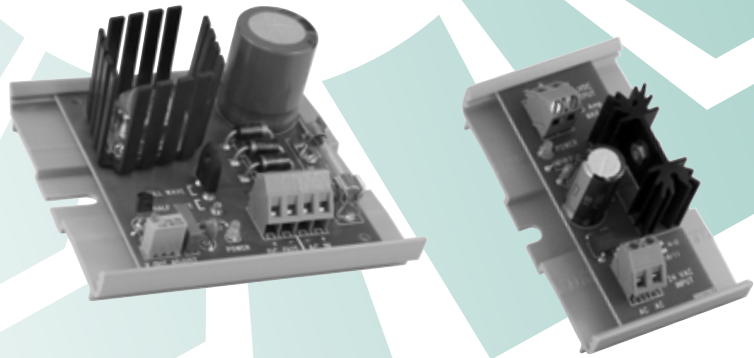

Precision power supplies

FEATURES:

- 24 Vac input/Vdc output
- Adjustable or fixed voltage output models
- Full-wave or half-wave rectified
- Snap track mounted
- Over-current protection

*Peace of mind
through reliable
power supplies*

GREYSTONE HAS AN **ISO 9001** REGISTERED QUALITY SYSTEM

PS1002

DESCRIPTION:

The PS1002 linear power supply accepts a 24 Vac input and outputs a regulated adjustable 24 Vdc to power devices such as humidity or temperature transmitters, gas detectors or loop-powered transducers. The PS1002 is field-selectable for full-wave or half-wave operation to suit various applications and features a power LED to indicate status.

SPECIFICATIONS:

Voltage Input	24 Vac, 50/60 Hz
Voltage Output	24 Vdc (field adjustable 3-26 Vdc)
Current Input	3.5 Amps max. (full-wave)
	2.3 Amps max. (half-wave)
Current Output.....	2.0 Amps max. (full-wave)
	1.0 Amps max. (half-wave)
Load Regulation.....	<1% at full rated current
Line Regulation	<0.5% at full rated current
Output Ripple.....	<20 mV at full rated current
Input Fuse Size	5 Amp (AGC-5)
Device Status	Green power ON LED
Operating Temperature	0 - 50 °C (32 - 122 °F)
Operating Humidity	5 to 95% RH, non-condensing
Mounting	Snap track included
Dimensions.....	102 L x 88 W x 43 H mm (4.0" x 3.45" x 1.7")
Weight.....	118 g (4.16 oz)

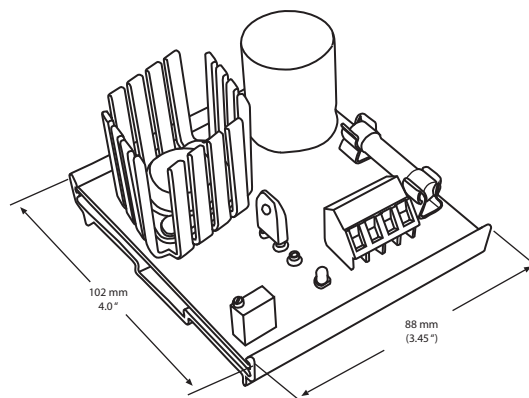

PS124F

DESCRIPTION:

The low-cost, dependable linear power supply, PS124F accepts a 24 Vac input and outputs a regulated 24 Vdc to power devices such as gas detectors, humidity or temperature transmitters, and other loop-powered transducers. The device is full-wave rectified so that the AC supply and DC output do not share the same ground.

SPECIFICATIONS:

Voltage Input	24 Vac, ±10%, 50/60 Hz
Voltage Output	24 Vdc (full wave rectified)
Current Output.....	0.5 Amps max. (0 - 40 °C/32 - 104 °F)
	0.35 Amps max. (40 - 50 °C/104 - 122 °F)
Load Regulation.....	1% at full rated current
Overload Protection	Regulated thermal shutdown
Operating Temperature	0 - 50 °C (32 - 122 °F)
Operating Humidity	5 to 95% RH, non-condensing
Mounting	Snap track included
Dimensions.....	82.6 L x 32 W x 28 H mm (3.25" x 1.26" x 1.1")
Weight.....	50 g (1.76 oz)

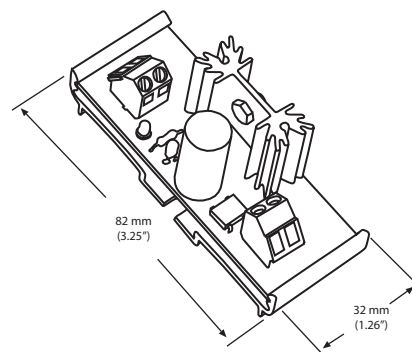

PRODUCT ORDERING INFORMATION

<input type="checkbox"/> PS1002	24 Vac/24 Vdc @ 2 Amps, full-wave or 1 Amp, half-wave (Jumper selectable)
<input type="checkbox"/> PS124F	24 Vac/24 Vdc @ 0.5 Amps, Fixed, full wave rectified



GREYSTONE

ENERGY SYSTEMS INC

Greystone Energy Systems, Inc.

RoHS
COMPLIANT



Greystone Energy Systems Inc. is one of North America's largest ISO registered manufacturers of HVAC/R sensors and transmitters for Building Automation Management Systems.

We have conscientiously established a worldwide reputation as an industry leader by maintaining leading-edge design technology, prompt technical support, and a commitment to on-time deliveries. We take pride in our Quality Management System which is ISO 9001 certified, assuring our customers of consistent product reliability.

GREYSTONE HAS AN **ISO 9001** REGISTERED QUALITY SYSTEM